

BANG BANG YOU'RE DEAD

(ABSOLUTE DARKNESS. A voice in the dark. After a moment, a flashlight explores the stage, moves along the bottom length, then up, finding Josh asleep on the jail bed. Josh jumps to his feet.)

JOSH

Who's there? Who is it? Who's there?

(Michael holds the flashlight under his chin illuminating only his face.)

MICHAEL

Why me?

JOSH

What is this? What is this?

MICHAEL

We played ball together. You were awesome on the field. You were unstoppable.

JOSH

Survival of the fittest, baby.

MICHAEL

And you were only a freshman. You could've been team captain in your senior year. Why'd you kill me? I never hurt you.

JOSH

It was more fun than droppin' dudes in a video game.

(Michael's flashlight goes out. Katie holds her flashlight under her chin.)

KATIE

Why me, Josh?

JOSH

Why not? World's overpopulated. I wanted to do my part.

KATIE

You liked me.

JOSH

Once upon a time.

KATIE

Why'd you have to kill me?

JOSH

Felt like it, okay? Happy now?

(Katie's flashlight goes out. Matt holds his flashlight under his chin.)

MATT

Why me?

JOSH

What is this?

MATT

Why me? I don't even know you.

JOSH

You were in the wrong place at the wrong time.

(Matt's flashlight goes out. Jessie holds her flashlight under her chin.)

JESSIE

Why me?

JOSH

Why not you? Everybody's gotta die sometime. Might as well get it over with.

(Jessie's flashlight goes out. Josh lays back on the bed. Emily leans over him, holds her flashlight under her chin. Josh springs up, surprised.)

EMILY

Why me, Josh? We live on the same street. We used to make mud pies together when we were little kids. I taught you how to blow bubbles with chewing gum. I came to your birthdays, you came to mine. When we were eleven you let me play war with you and the other boys because you liked how I died.

(Let the five deceased improvise pre-teen kids playing war, using their fingers for guns and making shooting sounds. They run around in the dark, their flashlights sweeping the floor, looking for the enemy, the lights criss-crossing. Let them shout "bam, bam you're dead" ("pow, pow" and other variants). Eventually Emily "kills" Katie and Matt who drop dead. Michael shoots Jessie who falls dead. Michael and Emily shoot each other at the same time. Michael drops dead at once. Emily dies very dramatically with all the appropriate sounds. Beat.)

EMILY (LYING ON FLOOR)

Hope I didn't disappoint you in the cafeteria this morning. Hope I died just right for you, Josh.

JOSH

You didn't have to fall on me and get me all bloody.

EMILY

Want to see it again? --Go on. Shoot me again.

(Josh pretends to shoot her. She dies again very dramatically.)

JOSH

Love that feeling.

ACTOR 2

Love it.

ACTOR 4

Crave it.

ACTOR 5

Need it.

ACTOR 2

Gotta have a gun grip in your hand.

(Chorus echoes the word "hand.")

JOSH

Always wanted to be an Army Ranger parachuting behind enemy lines, ever since I could hold a--

ACTOR 4

Cap gun.

ACTOR 5

Water gun.

ACTOR 2

Air gun.

ACTOR 4

Pop gun.

ACTOR 5

B.B. gun

JOSH

Twelve gauge.

ACTOR 2

22.

ACTOR 4

38.

ACTOR 5

45.

JOSH

A gun makes you feel alive.

(Chorus echoes "alive.")

Respect. ACTOR 2

Watch out! ACTOR 4

Move aside! ACTOR 5

Nobody can touch you. JOSH

When you have a gun-- ACTOR 2

Nobody mocks you. JOSH

When you have a gun-- ACTOR 4

You can take on anybody. JOSH

Anybody. ACTOR 5

The champ wrestler. ACTOR 2

The whole wrestling team. ACTOR 4

The bad dudes. ACTOR 5

Gang bangers. ACTOR 2

When you have a gun, people talk nice. JOSH

When you have a gun-- ACTOR 4

People look at you like a V.I.P. JOSH

(Chorus echoes "V.I.P.")

Somebody bumps you, they say, Excuse me. ACTOR 5

You walk different-- JOSH
When you have a gun. ACTOR 2
You talk different-- JOSH
When you have a gun. ACTOR 4
You think different-- JOSH
When you have a gun. ACTOR 5
It's so cool-- JOSH
When you have a gun. ACTOR 2
(Chorus loudly echoes "gun.")
It's an A-plus. ACTOR 4
Slam dunk. ACTOR 5
Touchdown. ACTOR 2
Put down. ACTOR 4
All in one. ACTOR 5
(Chorus echoes "one.")
Love that military stance! JOSH
You ain't got a chance-- ACTOR 2
Respect! ACTOR 4
Watch out! ACTOR 5

ACTOR 2

Move aside!

ACTOR 4

You can be whatever you wanna be--

JOSH

'Cause a gun in your hand is a Ph.D.

(Lights on Actor 1 and Actor 3 as Josh's parents. The deceased train their flashlight beams on the parents as they enter.)

ACTOR 3 (AS JOSH'S MOM)

Josh, there's no way we're buying you a rifle.

JOSH

Mom, will you listen to me?

ACTOR 1 (AS JOSH'S DAD)

First you had to have a p.c., then every video game ever made, then a laptop--

JOSH

For school, dad.

ACTOR 3 (AS JOSH'S MOM)

Then a cell phone, a beeper and the newest style Nikes every three months--

ACTOR 1 (AS JOSH'S DAD)

You have to have every CD you hear on the radio.

ACTOR 3 (AS JOSH'S MOM)

An expensive mountain bike you rode three times.

ACTOR 1 (AS JOSH'S DAD)

A snowboard you never used. And now a rifle? Please.

JOSH

Grandpa wants to take me hunting.

ACTOR 3 (AS JOSH'S MOM)

I'm absolutely against it.

JOSH

Grandpa hunts. Are you rejecting what your own father thinks?

ACTOR 1 (AS JOSH'S DAD)

Of course not.

JOSH

Then I should have the rifle, right?

ACTOR 3 (AS JOSH'S MOM)

I wish you felt as passionate about your grades as you do about a rifle.

JOSH

You're changing the subject.

ACTOR 1 (AS JOSH'S DAD)

You've got a high I.Q. Your B's and C's could be all A's.

JOSH

Will you get off my back about my I.Q.?

ACTOR 3 (AS JOSH'S MOM)

We might feel differently if you were living up to your full potential.

JOSH

Okay, you get me the rifle and I'll bring home all A's on my next report card. Deal?

ACTOR 3 (AS JOSH'S MOM)

We'll talk about a rifle when we see all A's.

JOSH

You don't even trust me.

ACTOR 3 (AS JOSH'S MOM)

Josh, you know that's not true.

JOSH

If you trust me, then get me the rifle now.

ACTOR 1 (AS JOSH'S DAD)

When you get all A's, we'll discuss it.

JOSH

Hunting season will be over before grades come out. Then I have to wait a whole year!

ACTOR 1 (AS JOSH'S DAD)

You have to learn patience.

JOSH

Hunting teaches patience. Grandpa said. But what's he know? He's only your father. All I want is to spend some time with grandpa and hear his stories about when he grew up. Learn some responsibility. Learn respect for firearms. How is all that bad?

ACTOR 1 (AS JOSH'S DAD)

It's not bad, Josh. It's just that we're not comfortable with guns.

JOSH

If I wanted to, I could get a gun in school for fifty bucks.

ACTOR 3 (AS JOSH'S MOM)

How?

JOSH

Easy. I know a kid who stole a gun from his father. But I wouldn't buy it because that would be wrong. Is this what I get for being honest?

ACTOR 3 (AS JOSH'S MOM)

Maybe his honesty deserves the rifle for a reward.

ACTOR 1 (AS JOSH'S DAD)

Maybe you shouldn't cave in every time Josh throws a tantrum.

ACTOR 3 (AS JOSH'S MOM)

What about the electric guitar you got him when he threw himself on the floor?

ACTOR 1 (AS JOSH'S DAD)

At least that showed an interest in music.

ACTOR 3 (AS JOSH'S MOM)

Yeah, and now it's collecting dust in the closet.

(Actors 1 and 3 walk off arguing.)

JOSH

Divide and conquer. Works every time. So don't blame me. Blame my folks, okay? They didn't have to buy me a rifle.

EMILY

You still didn't answer my question. Why me? Why did you kill me?

JOSH

It's simple math. My rifle holds five bullets. Five bullets, five people. Perfect.

MICHAEL

The bullet that killed me pierced my parents' hearts, too.

KATIE

Pierced my brothers' and sisters' hearts.

MATT

Pierced my friends hearts.

JESSIE

Pierced the hearts of parents who send their kids to school.

EMILY

Just five bullets wounded hundreds.

MICHAEL

Thousands.

KATIE

Wounds that bleed.

MATT

Wounds that weep.

JESSIE

Wounds that never heal.

EMILY

Wounds that are very real.

ALL

Thousands!

JOSH

Get lost.

(Josh lies down to sleep again. Emily pulls off his blanket.)

EMILY

That's not a good enough answer, Josh.

MICHAEL

And that's not fair.

KATIE

Not fair.

MATT

Not fair at all.

JESSIE

That our bodies lie in coffins.

EMILY

While you still breathe the air.

JOSH

Look at it this way: you got yourselves a cozy little place, and you can't beat the rent.

MICHAEL

It's not fair.

KATIE
Not fair.

MATT
Not fair at all.

JESSIE
That we're under the earth--

EMILY
And you don't even care.

JOSH
Know what's not fair? Some dude jumped me before I
had a chance to reload. I could've dropped a lot
more bodies and made history.

MICHAEL
We demand an honest answer, Josh. Why? Why'd you
kill us?

JOSH
It was fun.

(The deceased stand in a circle and push Josh around like
a ball.)

KATIE
You don't have the proper frame of mind.

MATT
We'll be all over you.

JESSIE
Up one side.

EMILY
Down the other.

MICHAEL
In your face.

KATIE
Under your skin.

MATT
Till you tell us why.

JESSIE
Why?

EMILY
Why'd you kill us?

JOSH
Lay off me.

A kid in a cage. MATT

In a zoo of misfits. JESSIE

Even until your release. EMILY

When you're a stooped-- MICHAEL

Broken-- KATIE

Bitter, old man. MATT

Full of scars. JESSIE

Scars on body and mind. MICHAEL

Friendless. KATIE

Hopeless. MATT

Mindless. JESSIE

Soul-less. EMILY

Some lawyer'll get me off. JOSH (LAUGHING)

If you survive. MICHAEL

Survive what? JOSH

Yo, bad boy. DRUMMER (AS CON)

You talking to me? My name's Josh. What's yours? JOSH

You the new dude that offed seven people? DRUMMER (AS CON)

JOSH

If that dude didn't jump me I had enough ammo on me to take out a hundred more. I'd've made history.

DRUMMER (AS CON)

Tomorr' we gonna see just how bad you are.

JOSH

What do you mean?

DRUMMER (AS CON)

You'll see what we mean, bad boy.

JOSH

(to himself)

Whoa.

MICHAEL

Feel your cell start to shrink?

KATIE

Feel the walls closing in?

MATT

Compressing your thoughts?

JESSIE

Cramming your brain?

EMILY

Driving you insane?

MICHAEL

You'll wish you were dead every so often.

KATIE

Your six by eight will be your coffin.

MATT

Nobody will hear.

JESSIE

When you scream and cry.

EMILY

Why? Why? Why'd you kill us?

JOSH

You can't hurt me. You're all dead.

MICHAEL

We need some answers, Josh.

KATIE

We want some answers tonight, Josh.

MATT

We want the truth.

JESSIE

The whole truth.

EMILY

And nothing but the truth.

JOSH

As the cop said, I have the right to remain silent. Anything I say can be held against me in a court of law.

(Quick drum rhythm. The deceased up-end the box converting it to a judge's bench by opening the lid so that it's up vertically. Actor 2 stands behind box and bangs the gavel. [Because the courtroom scene is just a fantasy, it should be played speeded up, without pause, so that Josh's nightmare trial is over in a matter of seconds.]

ACTOR 2 (AS JUDGE)

The court will hear the prosecutor's opening statement.

ACTOR 4 (AS PROSECUTOR)

Your Honor, ladies and gentlemen of the jury: seven dead bodies. Dozens of witnesses. What's to think about?

ACTOR 2 (AS JUDGE)

The court will now hear from the public defender.

ACTOR 1 (AS PUBLIC DEFENDER)

Josh was a good student, a popular student, a good son. There's only one explanation--temporary insanity.

ACTOR 4 (AS PROSECUTOR)

I call witnesses for the prosecution!

ACTOR 3 (AS WITNESS)

Josh pulled the wings off a butterfly when he was five and he plagiarized on a paper for English class.

ACTOR 2 (AS JUDGE)

The court will now hear closing statements.

ACTOR 4 (AS PROSECUTOR)

As I see it, you the jury have a very difficult choice between the electric chair and lethal injection.

ACTOR 1 (AS PUBLIC DEFENDER)
Ladies and gentlemen of the jury, he's just a child.
I urge you to put Josh in a psychiatric ward.

JOSH
I'm not psycho just because my parents forced me to
see a shrink. I knew what I was doing!

ACTOR 2 (AS JUDGE)
Ladies and gentlemen of the jury, have you reached
a verdict?

ACTOR 5 (AS JURY FOREWOMAN)
We have Your Honor. Life imprisonment without
possibility.

JOSH
Possibility of what?

ACTOR 5 (AS JURY FOREWOMAN)
Without possibility of anything good.

(Beat. Lights fade. Chorus exits. Deceased and Josh
remain.)

MICHAEL
You'll never achieve your dreams.

KATIE
Never skydive.

MATT
Never scuba off Australia.

JESSIE
Never explore the caldera of a volcano.

EMILY
Never fly a helicopter.

MICHAEL
Never be a sportscaster.

KATIE
Never ski again.

MATT
Never body surf.

JESSIE
Never meet people on the internet.

EMILY
Never know what you could've been--

Done-- MICHAEL

Seen-- KATIE

Had-- MATT

Known-- JESSIE

Loved in your lifetime. EMILY

MICHAEL
Now you'll never know all the happiness that was
yours.

But you'll wonder. KATIE

MATT
And the wonderment will eat you alive.

JESSIE
Eat you for breakfast.

EMILY
Eat you for lunch.

MICHAEL
Eat you for dinner.

KATIE
While all your dreams mock you--

MATT
Mock you--

JESSIE
Mock you--

EMILY
Mock you through the bars.

(The box is restored to a bed. Josh lies down to sleep
on the blanket.)

JOSH
Who cares? The whole thing will be off my record
when I'm eighteen anyway. Maybe I'll be out of here
when I'm twenty-one. You're all just a bad dream.

EMILY
Sometimes bad dreams come true.

(The deceased wrap Josh in the blanket, pick him up, making the box a coffin. They drop him in, close the lid. We hear Josh kicking and screaming inside. They turn the box on its side, open the lid. Josh tumbles out screaming and thrashing around. He begins to look at the deceased with new respect.)

MICHAEL

That's how it is under the earth.

KATIE

In the dark.

MATT

Alone.

JESSIE

In silence.

EMILY

We really need some answers, Josh.

JOSH

Answers to what?

MICHAEL

What were you thinking?

KATIE

What was in your heart?

MATT

Why'd you smile when you killed us?

JOSH

I'm just a friendly guy.

JESSIE

Didn't you feel badly?

EMILY

Did you think of the buck when you shot me?

(Josh is astonished they know about his hunting experience. The tone changes. Josh is feeling vulnerable that they know his mind.)

JOSH

What buck?

(The deceased pick up the box and move it to another location.)

MICHAEL

You know what buck.

KATIE
Your first time hunting.

MATT
With your grandpa.

JOSH
How do you know that?

JESSIE
We know everything about you.

EMILY
All your thoughts.

MICHAEL
Feelings.

KATIE
Memories.

MATT
Dreams.

JESSIE
We know all your deep, dark secrets.

JOSH
How? How can you know all that?

EMILY
We're all in your head.

JOSH
Psych! Tell me one fact about that day. Tell me
one thing grandpa said.

MICHAEL
Just you and grandpa in his old, red truck.

(Actor 1, as Grandpa, sits next to Josh on the box that
now becomes a truck.)

ACTOR 1 (AS GRANDPA)
Respect the animals. Don't take a shot unless you
know it's sure. Do it quick and clean. Otherwise
the animal suffers.

JOSH
Wow.

KATIE
That old logging road is full of ruts.

JESSIE

You both bounce on the seat. You can't wait to shoot your new rifle.

JOSH

I'm pumped.

MICHAEL

Grandpa parks the truck. You both sit there. Waiting for six a.m.

KATIE

Waiting to shoot your new rifle.

ACTOR 1 (AS GRANDPA)

Let's go, Josh.

MATT

You both get out of the truck. It's cold. You can see your breath.

JESSIE

Grandpa watches you load the rifle's magazine.

EMILY

Five shiny bullets.

MICHAEL

You show him the safety is on.

ACTOR 1 (AS GRANDPA)

Atta boy. You'll be a man by the end of the day.

KATIE

Grandpa pats your back.

MATT

You both head for the forest.

JESSIE

You see other hunters.

EMILY

All grown men with rifles.

ACTOR 1 (AS GRANDPA)

Now you wait here. Keep still. I'll drive the game towards you.

MICHAEL

You sit on a log for two hours.

(Josh sits on the floor.)

KATIE

Hours on a cold, wet log covered with moss.

MATT

Wishing you were still in a warm bed.

JESSIE

Wishing you ate the oatmeal your mother begged you to eat.

EMILY

Nose goes numb.

MICHAEL

Fingers go numb.

KATIE

Toes go numb.

MATT

And you have a profound thought:

JOSH

Hunting sucks.

JESSIE

You doze off.

EMILY

Doze for five, ten, fifteen minutes.

MICHAEL

Something wakes you up.

KATIE

Rustling of dry leaves.

MATT

You don't move.

JESSIE

The rustling leaves sound comes closer.

EMILY

And then you see it.

MICHAEL

A buck.

KATIE

Eight pointer.

JOSH

Like in a dream. Amazing.

MATT

Magnificent.

Strong. JESSIE

Proud. EMILY

Keen. MICHAEL

You forget you're hunting. KATIE

You're taken by its beauty. MATT

Utterly taken by its feral beauty. JESSIE

Its hot breath making weird ghosts in the cold air. EMILY

And then you notice the rifle in your hand. MICHAEL

You remember why you're there. KATIE

To kill. MATT

Kill the magnificent-- JESSIE

Kill the strong-- EMILY

Kill the proud-- MICHAEL

Kill the keen buck. KATIE

The time has come. MATT

Time to be a man. JESSIE

But deep inside you don't know if you can really pull the trigger. EMILY

But you must go home a man by the end of the day. MICHAEL

KATIE
Or stay a boy who plays bang, bang, you're dead.

JOSH
The buck sees me. Freezes.

MATT
You hear your heartbeat.

JESSIE
You raise your rifle.

(Josh mimes a rifle. GUNS IN ANY FORM MUST NEVER BE PART
OF THIS PLAY.)

EMILY
Can't find the buck in the scope--

MICHAEL
Because your hands are shaking.

KATIE
Hold your breath.

MATT
Crosshairs under the buck's shoulder.

JESSIE
The moment of truth has come.

EMILY
But this buck's too beautiful to kill.

MICHAEL
So you make your face a mask.

KATIE
A mask that hides your face.

MATT
A face that hides the pain.

JESSIE
A pain that eats your heart.

EMILY
A heart nobody knows.

MICHAEL
You pull the trigger! Nothing happens!

KATIE
The safety's still on!

MATT
You panic!

JESSIE
You click the safety off.

EMILY
The buck turns and runs like the wind.

MICHAEL
You take aim--

ALL DECEASED
Bam!

(On each "Bam," one loud drumbeat.)

KATIE
First shot misses!

ALL DECEASED
Bam!

MATT
Second shot misses.

ALL DECEASED
Bam!

JESSIE
Third shot misses!

ALL DECEASED
Bam!

EMILY
Fourth shot misses!

MICHAEL
Down on one knee.

KATIE
Find the buck in the crosshairs.

MATT
It is so beautiful.

JESSIE
Magnificent.

EMILY
Proud.

MICHAEL
Strong.

KATIE
All you want to be.

MATT
But the buck has to die so you can be a man--

JESSIE
Has to bleed.

EMILY
Has to fall.

MICHAEL
Has to die.

KATIE
So you can be a man.

ALL DECEASED
Bam!

(Final drumbeat.)

MATT
Buck goes down!

JOSH
Cool!

JESSIE
You tear across the field.

EMILY
Your eyes meet the buck's.

MICHAEL
You see who you used to be--

(Slight beat.)

KATIE
Full of fear--

MATT
Helpless.

JESSIE
Its chest heaves as blood pulses out like catsup--

EMILY
Its legs kick as if to run on the air.

MICHAEL
And it makes a pitiful sound that makes you hurt
inside--

KATIE
A cry that could be human.

JOSH
Awww, man.

MATT
You wish it was all a game.

JESSIE
A game.

EMILY
A video game.

MICHAEL
Just hit reset.

KATIE
And start again.

MATT
Start again.

JESSIE
Start all over again.

EMILY
Because it hurts to see a--

MICHAEL
Beautiful--

KATIE
Magnificent--

MATT
Proud--

JESSIE
Keen buck dying on the ground.

EMILY
You watch its life run out.

MICHAEL
Blood thick as catsup.

KATIE
And wish you could take it all back.

MATT
Take back the bullet.

JESSIE
Put back the blood.

EMILY
Restore the buck to its majesty.

MICHAEL

Give back its pride.

KATIE

Return its strength.

MATT

Make it keen once more.

JESSIE

Let it be what it is and run like the wind.

JOSH

I thought it would be fun. I didn't know it would be like this. Please don't die.

EMILY

Your buck takes its last breath...You almost let yourself weep.

MICHAEL

But you hear boots on dead leaves.

KATIE

Grandpa comes out of breath.

MATT

He sees your dying buck.

JESSIE

He looks at you like no one's ever looked at you before.

EMILY

Like a man.

MICHAEL

As promised.

KATIE

A man by the end of the day.

MATT

Grandpa takes out a camera.

ACTOR 1 (AS GRANDPA)

C'mon, Josh. Can't you smile in your moment of glory?

JESSIE

You stop your tears.

EMILY

And you pose for the camera.

MICHAEL

You make your face a mask.

KATIE

A mask that hides your face.

MATT

A face that hides the pain.

JESSIE

A pain that eats your heart.

EMILY

A heart nobody knows.

(Actor 1, as Grandpa, takes a polaroid picture, hands it to Josh.)

MICHAEL

Now you have proof of who you are.

JESSIE

You carry the snapshot everywhere.

(Deceased carry the box back to original place.)

EMILY

You want the world to see you and your buck.

KATIE

You're dying to tell the story.

MATT

The story of how you took it down.

JESSIE

How you took its magnificence.

EMILY

Took its pride.

KATIE

Took its strength.

MATT

Made it part of you.

JESSIE

Part of your mask.

EMILY

The kid that nobody knows.

(Lights on Katie writing in a notebook. Enter Josh.)

JOSH

Hey, Katie.

KATIE

Hi.

JOSH

Writing your thing for speech class?

(she goes back to her work)

Guess what I wrote about.

(hands her the snapshot)

The buck I killed last weekend. Man, it was so cool. What's yours on?

KATIE

How to dump somebody.

JOSH

How's it go?

KATIE

Say for example your boyfriend says he's gonna meet you at the mall and take you to a movie but instead he goes hunting.

JOSH

C'mon, Katie. We could go out this coming weekend.

KATIE

I don't think we should see each other anymore.

JOSH

Can't you give me another chance?

KATIE

I like somebody else now.

JOSH

Who?

KATIE

What's it matter?

JOSH

Just tell me who.

KATIE

Doesn't matter.

JOSH

Matters to me.

KATIE

Believe it or not there are some people who don't take me for granted.

(Enter Michael.)

MICHAEL

Sorry I'm late. Hey, Josh.

JOSH

Him? It's him? I thought we're friends?

MICHAEL

We are.

JOSH

Some friend who sneaks around with my girl.

KATIE

I'm not yours.

MICHAEL

Nobody's sneaking around, Josh.

KATIE

Can we just go please?

(Josh pushes Michael who pushes him back and knocks Josh to the ground. HUGE LAUGH FROM THE RUMORS. Exit Katie and Michael hand in hand. Lights on Josh. Voices in the dark. Constant rhythm from the drum under all rumors.)

ACTOR 1/RUMOR

Hear about Josh?

ACTOR 2/RUMOR

No, what about him?

ACTOR 3/RUMOR

Killed a buck.

ACTOR 4/RUMOR

No wonder he walks around all big and bad.

ACTOR 5/RUMOR

Not anymore.

ACTOR 1/RUMOR

What happened?

ACTOR 2/RUMOR

Katie dumped him for Michael.

ACTOR 3/RUMOR

Whoa! How'd Josh take it?

ACTOR 4/RUMOR

Like he doesn't care.

(Let the following rumor lines overlap in succession:
Actor 5 begins, "I wonder..." Cue Actor 1 with, "What?
Josh..." Cue Actor 2, "What? The..." And so on till
the line, "What a dork," which should stick out.)

ACTOR 5/RUMOR

I wonder if he really killed the buck.

ACTOR 1/RUMOR

What? Josh didn't shoot the buck?

ACTOR 2/RUMOR

What? The snapshot's a fake?

ACTOR 3/RUMOR

What's a fake?

ACTOR 4/RUMOR

The snapshot!

ACTOR 5/RUMOR

Josh never shot a buck?

ACTOR 1/RUMOR

I think he shot the bull.

ACTOR 2/RUMOR

What a dork!

(The voices in the dark laugh mockingly.)

JOSH

Every kid in school is laughing at me.

MICHAEL

So you make your face a mask.

KATIE

A mask that hides your face.

MATT

A face that hides the pain.

JESSIE

A pain that eats your heart.

EMILY

A heart nobody knows.

(Voices in the dark laugh.)

JOSH

Someday, somebody's gonna laugh once too many times.

(All laugh. Josh mimes loading a rifle, aims at the laughter, fires three times, each shot highlighted with a loud drumbeat outside the rhythm. The laughter stops abruptly after the third shot. Deceased shine flashlights at Josh. Drum out.)

MICHAEL

Who are you killing, Josh?

JOSH

You see anybody bleeding?

KATIE

Who are you killing in your mind?

JOSH

Nobody. Anybody. Everybody.

MATT

Are you stuck in the movie again?

JOSH

What movie?

JESSIE

Your favorite movie.

JOSH

How would you know my favorite movie?

EMILY

The movie that makes the pain go away.

JOSH

How's it go?

MICHAEL

The kid goes back to school with a shotgun.

JOSH

And?

KATIE

Blows away all the kids who mocked him the day before.

JOSH

Shut up.

MATT

Blows away the teacher too.

JOSH

Get out of my face.

JESSIE

Why are you cutting gym class?

JOSH

Maybe I got something better to do.

EMILY

Like sneak down the empty hallway?

MICHAEL

Like sneak in an empty classroom?

(Josh uses the fourth wall as a blackboard, mimes writing on it with a piece of chalk.)

KATIE

What are you writing on the blackboard?

JOSH

(speaking words as he writes them:)

"Everybody...in...this...class...is...dead...meat."

MATT

Do you enjoy making everyone afraid?

JOSH

It's just for laughs.

JESSIE

Except nobody's laughing.

JOSH

I am! And they're not laughing anymore.

EMILY

You enjoy police coming to investigate?

JOSH

More than I can say!

(Short drum rhythm. A police siren blares as a red flasher sweeps the stage. Josh laughs.)

ACTOR 5 (AS COP)

Alright, I want everyone to stand by his or her locker. This your locker?

JOSH

Yes, officer.

ACTOR 5 (AS COP)

You know anything about the words on the blackboard?

JOSH

No, officer.

ACTOR 5 (AS COP)
 You sure?

JOSH
 Positive.

ACTOR 5 (AS COP)
 You see anybody go in or come out of the classroom?

JOSH
 No.

ACTOR 5 (AS COP)
 Where were you when the words were written on the blackboard?

JOSH
 I'd have to know when the words were written, wouldn't I, officer?

ACTOR 5 (AS COP)
 Let us know if you hear anything.

(Lights on Josh laughing. Voices in the dark. Drum rhythm under rumors.)

ACTOR 1/RUMOR
 The principal's calling an assembly.

ACTOR 2/RUMOR
 What for?

ACTOR 3/RUMOR
 Maybe they found out who did it.

ACTOR 5/RUMOR
 That's what I heard.

ACTOR 1/RUMOR
 Don't know--but he's gonna be hauled up on stage in front of the whole school and suspended on the spot.

JOSH
 (laughing)
 Gotta find him first.

ACTOR 2/RUMOR
 They should take away all the guns.

(Lines begin overlapping again.)

ACTOR 3/RUMOR
 Ever hear of the Constitution and the right to bear arms?

ACTOR 4/RUMOR
How are we supposed to get an education dodging
bullets?

ACTOR 5/RUMOR
It's all a hoax.

ACTOR 1/RUMOR
Ever hear of Paducah?

ACTOR 2/RUMOR
What about Jonesboro and Springfield?

ACTOR 3/RUMOR
It could happen anywhere.

ACTOR 4/RUMOR
There's a killer in every school.

ACTOR 5/RUMOR
Teachers should carry guns.

ACTOR 1/RUMOR
Yeah, and we should all wear bulletproof vests.

(Josh stands amid the actors 1-4 and the deceased who
make idle chatter like kids gathering in the auditorium.
Deceased shine flashlight on Principal as she enters.
New drum rhythm at entrance, then drum out.)

ACTOR 5 (AS PRINCIPAL)
(Repeat)
Alright people, let's settle down...

ACTOR 2
You're sweating, Josh.

JOSH
It's hot in here, okay?

(Flashlights out.)

ACTOR 5 (AS PRINCIPAL)
Someone in this auditorium wrote some very
threatening words on the blackboard. Perhaps the
blackboard phantom wrote those words in jest,
perhaps in anger. Whatever the case...

JOSH
Blackboard phantom! Love that!

ACTOR 5 (AS PRINCIPAL)
...If the guilty party surrenders in my office
sometime today, the punishment will be minimal...

ACTOR 3

Maybe she knows it's you, Josh.

JOSH

If she knew it was me, she wouldn't say it like that.

ACTOR 5 (AS PRINCIPAL)

But if we discover who he or she is...The punishment will be severe. If you know who the blackboard phantom is and don't tell us, you will be just as guilty.

ACTOR 4

She's looking at you, Josh.

JOSH

And I poker-face her right back.

MICHAEL

So you make your face a mask.

KATIE

A mask that hides your face.

MATT

A face that hides the pain.

JESSIE

A pain that eats your heart.

EMILY

A heart nobody knows.

(Lights on Josh. Drum rhythm under rumor lines. Voices in the dark. Deceased gather behind Josh.)

ACTOR 1/RUMOR

Who could it be?

ACTOR 2/RUMOR

I think it's Randy.

ACTOR 3/RUMOR

How do you know?

ACTOR 4/RUMOR

The look in his eye.

DECEASED

Paducah, Jonesboro, Springfield.

(Josh, uneasy, crosses away, but still enjoys the rumors. Deceased follow.)

ACTOR 5/RUMOR

They don't have a clue!

ACTOR 1/RUMOR

Who could it be?

ACTOR 2/RUMOR

Anybody in this school.

ACTOR 3/RUMOR

My parents want me to stay home till the killer's found.

ACTOR 4/RUMOR

What killer? Nobody's dead.

DECEASED

Paducah, Jonesboro, Springfield.

(Josh moves away from them again. Deceased follow again, but not so closely, perhaps upstage.)

ACTOR 5/RUMOR

You lucked out. Wish my parents felt that way.

(Lines begin to overlap again, building in intensity. Josh enjoys them thinking he's finally escaped the deceased.)

ACTOR 1/RUMOR

We're all just waiting for a massacre to happen.

ACTOR 2/RUMOR

We shouldn't talk about it.

ACTOR 3/RUMOR

Why not?

ACTOR 4/RUMOR

Maybe we could make it happen if we keep talking about it.

ACTOR 5/RUMOR

We need some excitement around here.

ACTOR 1/RUMOR

That's stupid.

ACTOR 2/RUMOR

For all I know, you're the killer.

ACTOR 3/RUMOR

Yeah, and maybe it's you.

ACTOR 4/RUMOR

Who knows? This could be the last day of my life.

ACTOR 5/RUMOR

I think it's Melissa.

ACTOR 1/RUMOR

Why do you say that?

ACTOR 2/RUMOR

Her locker is right next to the classroom.

ACTOR 3/RUMOR

I was with Melissa all day.

ACTOR 4/RUMOR

Then maybe you and Melissa did it together.

DECEASED

Paducah, Jonesboro, Springfield.

(From behind Josh, they startle him.)

JOSH

Love to see 'em squirm! It's killing me not to tell.

(Deceased, except Katie, step back as area lights go up on Katie reading a book. Josh turns to see her there.)

JOSH

Hey, Katie.

(Katie looks at Josh, beat, goes back to her book.)

JOSH

Can't you say hi?

KATIE

Hi.

JOSH

Wha'cha doin'?

KATIE

Duh.

JOSH

Wanna go for a pizza after school?

KATIE

Michael wouldn't like that.

JOSH

Tell you the truth, I wasn't thinking of bringing him along.

KATIE

Excuse me. I'm busy.

JOSH

Who do you think it is?

Who?
KATIE

The blackboard phantom.
JOSH

I have no idea, but he did me a favor.
KATIE

How?
JOSH

Calculus class was cancelled for the assembly. I wasn't ready for the test.
KATIE

I know who it is.
JOSH

Give him my regards.
KATIE

I will.
JOSH

Who is it?
KATIE

Promised I wouldn't tell.
JOSH

You're just a lot of talk.
KATIE

Think so?
JOSH

Know so. Who's he mad at? Who's gonna be dead meat?
KATIE

He didn't say but he's like Santa Claus--making a list, checking it twice.
JOSH

List of what?
KATIE

Names to write on the bullets. Every bullet has somebody's name on it.
JOSH

Why would the blackboard phantom confide in you?
KATIE

We're buds.
JOSH

You're full of it. KATIE

Think so? JOSH

Know so. KATIE

You're wrong. JOSH

Who is it? KATIE

I promised. JOSH

You don't know. KATIE

You won't tell? JOSH

No. KATIE

Promise? JOSH

Yes. KATIE

Cross your heart and hope to die? JOSH

Yes. KATIE

You'll be the only person who knows besides me. JOSH

Who is it? KATIE

You're lookin' at him. JOSH

(Katie laughs and exits. The chorus laughs mockingly.
Josh confronts them.)

Anybody wanna laugh in my face? JOSH
(Chorus goes silent)
That's what I thought. There's a potential killer
on the loose! Wonder who he or she is?

(Josh turns to find the school principal in his face.)

ACTOR 5 (AS PRINCIPAL)

Can I speak with you in my office, Josh? Come in.
Have a seat.

JOSH

Thanks.

ACTOR 5 (AS PRINCIPAL)

Anything you want to say to me?

JOSH

Not really.

ACTOR 5 (AS PRINCIPAL)

You sure?

JOSH

Oh, yeah. Great hair.

ACTOR 5 (AS PRINCIPAL)

Anything else?

JOSH

Well, yes, there is something.

ACTOR 5 (AS PRINCIPAL)

Good. What's that?

JOSH

We all really hope you catch that nut who wrote on
the blackboard.

ACTOR 5 (AS PRINCIPAL)

You do?

JOSH

We'll all feel better knowing we're safe.

ACTOR 5 (AS PRINCIPAL)

We know for a fact that you're the blackboard
phantom, Josh.

(Josh laughs)

You want to confess?

JOSH

I was in gym class.

ACTOR 5 (AS PRINCIPAL)

The instructor said you took a very long bathroom
break.

JOSH

You can't prove a thing.

ACTOR 5 (AS PRINCIPAL)
We have a snitch.

JOSH
Who?

ACTOR 5 (AS PRINCIPAL)
You.

JOSH
What?

ACTOR 5 (AS PRINCIPAL)
We compared the writing on the blackboard to your last essay in English class. It's a perfect match.

JOSH
Katie, right? Wasn't it Katie?

ACTOR 5 (AS PRINCIPAL)
Do you want to make it easy and confess?

JOSH
Why confess when I didn't do anything?

ACTOR 5 (AS PRINCIPAL)
It's tragic when a gifted young man throws away an education--for what? A childish prank. You know about our zero tolerance policy of violence or even the threat of violence. I have no choice but to expell you for the rest of the year.

JOSH
Because of some stupid words on the blackboard I have to repeat the grade?

ACTOR 5 (AS PRINCIPAL)
Not if you make it up in summer school.

(Josh backs away screaming "I won't go" as Chorus laughs mockingly. Lights off Actor 5. Lights on Actor 1 and 3 as Josh's parents.)

JOSH
I won't go! I won't go!

ACTOR 3 (AS JOSH'S MOM)
Josh, you will go to summer school no matter what.

JOSH
Sit in hot class all day while other kids can do what they want? And study on summer nights?

ACTOR 1 (AS JOSH'S DAD)
You should've thought about that before you wrote on the blackboard.

ACTOR 3 (AS JOSH'S MOM)
And you're grounded, Josh.

JOSH
For how long?

ACTOR 3 (AS JOSH'S MOM)
All summer.

JOSH
I can't go hunting with grandpa?

ACTOR 1 (AS JOSH'S DAD)
You broke your promise. We've taken your rifle away.

JOSH
I'd rather be dead!

ACTOR 3 (AS JOSH'S MOM)
Oh, Josh, you don't really mean that.

JOSH
You'll see if I mean it! You'll all see! I can take only so much! Expelled! Summer school! Off the football team! Kids laughing at me! No hunting! I'm pushed to my limits!

ACTOR 1 (AS JOSH'S DAD)
I think you should calm down.

JOSH
I want my rifle back. You gave it to me.

ACTOR 1 (AS JOSH'S DAD)
We're sorry. You'll get it back when we see a real change in your attitude.

JOSH
It was a gift. At least you said it was. Guess I can't believe a word you say.

ACTOR 3 (AS JOSH'S MOM)
You're in enough trouble, Josh. Don't make it any worse.

JOSH
I hate you both. I wish you would just die so I wouldn't have to look at you anymore.

(Josh mimes a pistol with his hand, shoots them both.)

ACTOR 1 (AS JOSH'S DAD)
You can't talk that way to us anymore. Go to your room!

JOSH

No! Why do you have to take away the thing that means the most to me?

ACTOR 1 (AS JOSH'S DAD)

Because we've raised you wrong. We tried to give you a good life but all we did was feed your appetites.

JOSH

Where is it? Where's my rifle?

ACTOR 1 (AS JOSH'S DAD)

It's locked up. And if your attitude doesn't improve, we'll sell it.

ACTOR 3 (AS JOSH'S MOM)

And starting tomorrow morning you have an appointment with a psychotherapist.

JOSH

Summer school. No rifle. No friends. No phone. Psycho torture. Dis of dises. It's over. My life is over. It's over.

(Josh throws a tantrum pounding on the floor shouting "It's over." Lights on Actor 4 as Psychotherapist.)

ACTOR 4 (AS PSYCHOTHERAPIST)

How are you, Josh?

JOSH

How good could I be if I'm forced to see a psychotherapist?

ACTOR 4 (AS PSYCHOTHERAPIST)

Don't you want to get to the bottom of your problems?

JOSH

I have nothing to say to you.

ACTOR 4 (AS PSYCHOTHERAPIST)

Why not?

JOSH

If I told you then I would have something to say, wouldn't I? Duh.

ACTOR 4 (AS PSYCHOTHERAPIST)

I've talked to some people at your school.

JOSH

Talked to who?

ACTOR 4 (AS PSYCHOTHERAPIST)

Your football coach praised your team spirit. Despite your need to be the class clown, your teachers say you're very bright and pleasant. You have had amazing grades in the past. There's a rumor that you're a big hit with the girls.

JOSH

I broke a few hearts.

ACTOR 4 (AS PSYCHOTHERAPIST)

With all of that going for you, why did you make a threat on the blackboard?

JOSH

Why'd the chicken cross the road?

ACTOR 4 (AS PSYCHOTHERAPIST)

I give up.

JOSH

To prove it wasn't chicken.

ACTOR 4 (AS PSYCHOTHERAPIST)

Why'd the monkey fall out of the tree?

JOSH

Don't know?

ACTOR 4 (AS PSYCHOTHERAPIST)

It died. Why'd the second monkey fall out of the tree?

JOSH

Don't know.

ACTOR 4 (AS PSYCHOTHERAPIST)

It died. Why'd the third monkey fall out of the tree?

JOSH

It died.

ACTOR 4 (AS PSYCHOTHERAPIST)

No. Peer pressure.

JOSH

Ha, ha, ha.

ACTOR 4 (AS PSYCHOTHERAPIST)

Why did you write on the blackboard, Josh?

JOSH

Maybe it's my childhood. Maybe it's my genes. Maybe it's my zodiac. Maybe the Devil made me do it.

ACTOR 4 (AS PSYCHOTHERAPIST)
Maybe you just chose to do it and it's nobody's
fault but your own.

JOSH
I don't like you.

ACTOR 4 (AS PSYCHOTHERAPIST)
That's not required. But it is required you tell
the truth. Did you mean what you wrote on the
blackboard? Is there somebody you want to turn into
dead meat?

JOSH
Why'd the chicken cross the road?

ACTOR 4 (AS PSYCHOTHERAPIST)
To avoid answering questions.

JOSH
I'm outta here.

ACTOR 4 (AS PSYCHOTHERAPIST)
You need psychotherapy sessions to get back into
school.

JOSH
Maybe I'm not going back to school.

ACTOR 4 (AS PSYCHOTHERAPIST)
Oh? What will you do?

JOSH
Maybe I'll join a gang.

ACTOR 4 (AS PSYCHOTHERAPIST)
Don't you think that's self-destructive?

JOSH
So what. My life is junk. Maybe I'll just kill
myself.

ACTOR 2 (VOICE IN THE DARK)
Boom. No more pain.

ACTOR 5 (VOICE IN THE DARK)
Hear about Josh?

ACTOR 2 (VOICE IN THE DARK)
No, what now?

ACTOR 5 (VOICE IN THE DARK)
Blew out his brains.

ACTOR 2 (VOICE IN THE DARK)
What a loser.

Always was a weenie. ACTOR 5 (VOICE IN THE DARK)

You think about suicide, Josh? ACTOR 4 (AS PSYCHOTHERAPIST)

Sometimes. JOSH

Like when? ACTOR 4 (AS PSYCHOTHERAPIST)

When I hear the voices. JOSH

What voices? ACTOR 4 (AS PSYCHOTHERAPIST)

Voices. I can just imagine what they must be saying about me. JOSH

Voices in the air or voices in your head? ACTOR 4 (AS PSYCHOTHERAPIST)

In my head. JOSH

Whose voices? ACTOR 4 (AS PSYCHOTHERAPIST)

Kids. JOSH

Kids you know? ACTOR 4 (AS PSYCHOTHERAPIST)

Kids, kids, all the kids at school. JOSH

Why does that bother you? ACTOR 4 (AS PSYCHOTHERAPIST)

It just does, okay? JOSH

Hear about Josh? ACTOR 2 (VOICE IN THE DARK)

No, what? ACTOR 5 (VOICE IN THE DARK)

Principal made 'em see a shrink. ACTOR 2 (VOICE IN THE DARK)

ACTOR 5 (VOICE IN THE DARK)
Blackboard phantom's doin' summer school.

ACTOR 2 (VOICE IN THE DARK)
The great hunter's gotta repeat the grade.

(All laugh.)

ACTOR 4 (AS PSYCHOTHERAPIST)
Josh, I'd really like to run some medical tests to see if we can relieve your pain with medication. You'll have to stay overnight in the hospital.

JOSH
The looney bin? You know how much face I'll lose with kids at school when they find out I'm a nut case? My life sucks.

(All laugh.)

ACTOR 4 (AS PSYCHOTHERAPIST)
Why'd the monkey fall out of the tree?

JOSH
Because I shot it dead!

(Lights off Actor 4.)

JOSH
Stupid! Stupid! Stupid!
(Voices laugh mockingly)
Wish somebody would put me out of my misery!

(After a moment of absolute silence--)

ACTOR 2 (VOICE IN THE DARK)
Boom.

JOSH
Who's there?

ACTOR 4 (VOICE IN THE DARK)
Boom.

ACTOR 2 (VOICE IN THE DARK)
No more pain...

JOSH
Who said that?

ACTOR 4 (VOICE IN THE DARK)
You.

ACTOR 2 (VOICE IN THE DARK)
Your life is over, Josh.

Over. ACTOR 4 (VOICE IN THE DARK)

Over. ACTOR 2 (VOICE IN THE DARK)

Over. ACTOR 4 (VOICE IN THE DARK)

Who's there? JOSH

You. ACTOR 4 (VOICE IN THE DARK)

You. ACTOR 2 (VOICE IN THE DARK)

You. ACTOR 4 (VOICE IN THE DARK)

Do it in the living room for your parents to see. ACTOR 2 (VOICE IN THE DARK)

(Drum returns softly.)

What do you mean? JOSH

Leave your brains on the wall. ACTOR 4 (VOICE IN THE DARK)

Make 'em feel bad. ACTOR 2 (VOICE IN THE DARK)

The rifle's locked in the closet. ACTOR 4 (VOICE IN THE DARK)

Break the lock. ACTOR 2 (VOICE IN THE DARK)

Boom. ACTOR 4 (VOICE IN THE DARK)

No more pain. ACTOR 2 (VOICE IN THE DARK)

That's dumb. JOSH

Josh the joke will be a year behind all his friends. ACTOR 4 (VOICE IN THE DARK)

(Voices laugh mockingly.)

ACTOR 2 (VOICE IN THE DARK)
While everybody's having fun in the sun, Josh is
reading gobble-de-gook in a book!

(Voices laugh mockingly.)

JOSH
Shut up! Stop it!

ACTOR 4 (VOICE IN THE DARK)
Only you can make them stop, Josh.

JOSH
How?

ACTOR 2 (VOICE IN THE DARK)
You know.

JOSH
What do you mean?

ACTOR 4 (VOICE IN THE DARK)
Boom.

JOSH
Whoa.

ACTOR 2 (VOICE IN THE DARK)
One bullet would quiet them forever.

(Voices laugh mockingly. Drum returns.)

ACTOR 4 (VOICE IN THE DARK)
You'd end your pain and stop the voices in your head.

JOSH
I don't want to be thinking this!

(Voices laugh mockingly.)

ACTOR 2 (VOICE IN THE DARK)
Show 'em who you are. The whole school would stand
in awe of you. You'd be a legend for years to come.

ACTOR 4 (VOICE IN THE DARK)
Kill the voices, Josh.

JOSH
Does it hurt?

ACTOR 2 (VOICE IN THE DARK)
Bullet in the head? You'll never feel a thing.

JOSH
I'm scared.

(Voices laugh mockingly.)

JOSH

How do I do this?

(Drum out.)

MICHAEL

Make your face a mask.

KATIE

A mask that hides your face.

MATT

A face that hides the pain.

JESSIE

A pain that eats your heart.

EMILY

A heart nobody knows.

JOSH

Here goes...But suppose I botch it?

(Voices laugh mockingly.)

ACTOR 4 (VOICE IN THE DARK)

You'll be a joke.

ACTOR 1 (VOICE IN THE DARK)

Hear about Josh? Tried to off himself but he blew it!

(Voices laugh mockingly.)

ACTOR 3 (VOICE IN THE DARK)

Now he's a pathetic wannabe forever!

ACTOR 4 (VOICE IN THE DARK)

Josh the joke!

(Voices laugh mockingly.)

JOSH

I can't do this! I'll be Josh the joke forever!

ACTOR 2 (VOICE IN THE DARK)

Then you have to stop the voices another way, Josh.

JOSH

How?

ACTOR 4 (VOICE IN THE DARK)

Two boxes of bullets should do it. It's almost lunchtime.

JOSH

Whoa...They'll all be in the cafeteria now.

ACTOR 2 (VOICE IN THE DARK)

Imagine their faces when the hunter walks in. They see you in camo holding your rifle. Instant respect. Judgment day.

JOSH

Like the movie.

ACTOR 1 (VOICE IN THE DARK)

Paducah.

ACTOR 3 (VOICE IN THE DARK)

Jonesboro.

ACTOR 5 (VOICE IN THE DARK)

Springfield.

ACTOR 4 (VOICE IN THE DARK)

Take 'em with you.

ACTOR 2 (VOICE IN THE DARK)

With you.

ACTOR 5 (VOICE IN THE DARK)

With you.

JOSH

Whoa. Nobody could top that.

ACTOR 4 (VOICE IN THE DARK)

You don't hear the voices laughing anymore, do you, Josh?

ACTOR 1 (AS JOSH'S DAD, VOICE IN DARK)

Josh? You home?

(Drum returns. Voices laugh mockingly in a rising crescendo with the drum.)

JOSH

Who's that?

ACTOR 2 (AS JOSH'S DAD, VOICE IN DARK)

Josh? You home?

ACTOR 1 (VOICE IN THE DARK)

They'll take you to the looney bin!

(Lights on Actor 1 as Josh's dad.)

ACTOR 1 (AS JOSH'S DAD)
Josh, the doctor called me at work and asked your mother and I to drive you to the hospital...How'd you get the rifle?

ACTOR 2 (VOICE IN THE DARK)
Don't chicken out now!

ACTOR 4 (VOICE IN THE DARK)
Unless you wanna be Josh the joke.

ACTOR 1 (AS JOSH'S DAD)
Put that down!

(Actor 1 advances. The drum rises to a crescendo.)

DECEASED AND CHORUS
DEAD! DEAD! DEAD!

(Lights out on Actor 1. He turns back to the audience and stands still.)

JOSH
What did I do?

ACTOR 3 (AS JOSH'S MOM, VOICE IN DARK)
Josh? What was that noise?

JOSH
Mom?

(Lights on Actor 3 as Josh's mom.)

ACTOR 3 (AS JOSH'S MOM)
Josh, what have you done?

MICHAEL
Make your face a mask.

KATIE
A mask that hides your face.

MATT
A face that hides the pain.

(Actor 3 as Josh's mom kneels and gestures to the body we can't see.)

JESSIE
A pain that eats your heart.

EMILY
A heart nobody knows.

JOSH
I love you, mom.

(Josh flicks the flashlight twice.)

DECEASED AND CHORUS

DEAD! DEAD!

(Actor 3 turns her back to the audience. All lights off. Josh holds the flashlight under his chin as he speaks to the turned backs of his parents.)

JOSH

Mom?

(A female voice in the dark starts to hum and then sing "Twinkle Twinkle Little Star" under the monologue)

Dad? You made me do this. I wanted to kill you but I didn't want you dead. How else could I tell you what's on my mind without you interrupting? Mom? How are you singing now if you're dead? Stop it. You used to sing that to me when I couldn't sleep. Stop it, please? Don't I have enough pain? Isn't it hard enough being nobody? Isn't it tough enough that everybody looks at me like I'm a broken trashbag? Where do I fit in? Where can I go and not have anybody on my back? At school the teachers are giving this test and that paper and don't do this and don't do that. Then I come home and you always find something that I didn't do and I'm never good enough. I guess I'm just sick of you being disappointed in me all the time. Remember when you taught me the outfielders glove, dad, and I caught a high-fly in the Little League championship game and you carried me off the field? Why can't it be like that? Why's it so easy to talk to you now? Anyway, thanks for listening.

(Chorus exits. The five deceased enter one by one, now each wearing white; Matt in a white dress shirt, Katie in a white blouse, Jessie in a white t-shirt, Michael in a white sweatshirt and white baseball cap turned backwards, Emily in a white sweatshirt. Matt enters first, carries a bottle of catsup, sits, pours some on some imaginary fries, begins to eat, then starts on some homework. Katie enters, sits next to Matt and asks to borrow a homework assignment, Matt agrees, but asks her to wait till he finishes the problem he's working on. Michael enters asking Katie to go with him to get some food, Jessie rushes in to tell Matt she's been accepted to college. Emily stops by to tell Katie she'll be late, etc. Improvise casual dialogue but don't allow anything to affect plot or character. As the dialogue builds to a crescendo, Matt, desperately trying to concentrate on his homework, finally raises his voice and asks them to be quiet so he can do his work. Silence, then together everyone continues at the same volume and pace. Matt slumps in defeat.

Lights up on Josh only, in a military stance. Silence.
Beat. Katie takes her flashlight, turns it on under her
chin.)

KATIE

Why me? You liked me.

JOSH

You snitched on me.

KATIE

Why do you have to shoot me through the heart?

(Michael squeezes catsup into Katie's hand. She smears
it on her heart.)

JOSH

Where do you think you shot me? Why do you pretend
I'm not there? My parents don't see me. Kid's in
school don't see me. You don't see me. I'm
invisible sometimes.

(Michael steps forward, flashlight under chin.)

MICHAEL

Why me? I had a football scholarship.

JOSH

You were everything I wanted to be.

(Jessie squeezes catsup into Michael's hand. He slaps it
on his hat, on the side of his head.)

MICHAEL

Why do you have to shoot me through the head?

JOSH

You should have figured that when you pushed me.

(Jessie steps forward, flashlight under her chin.)

JESSIE

Why me? I don't even know you.

(Matt squeezes catsup into her hand)

I never even spoke to you. Why me? What right do
you have to take all the life I could've lived?

(slaps catsup on her abdomen)

Feel like a man when you shot me in the stomach?

(Matt and Emily squeeze catsup in their own hands during
Jessie's line.)

JOSH

You have no idea what it's like to be somebody one
day, and nobody the next.

(Matt steps forward, flashlight under his chin.)

MATT

Why me? I had my whole life before me.

JOSH

So did I.

MATT

(Matt squeezes catsup on his shirt collar)
How'd it feel to shoot me through the neck?

JOSH

Don't know.

(Emily steps forward, flashlight under her chin.)

EMILY

All my life I've been taught to forgive. That forgiveness is for the forgiver. But I just can't. Not until I know what's really in your heart. I need to know, Josh. Why me?

(slaps it on her chest)

Why me?

JOSH

If you know all my thoughts, why don't you know that?

EMILY

We want to hear you say it to yourself...Why, Josh?

MICHAEL

Why her?

KATIE

Why him?

MATT

Why them?

JESSIE

Why me?

EMILY

Why anybody, Josh?

JOSH

Sometimes I hate being alive, but I'm afraid to be dead.

KATIE

Know what I hate about being dead? You can't call up and order a pizza.

(Deceased gather around the box casually.)

Pepperoni. MICHAEL

Extra cheese. JESSIE

Garlic. EMILY

Hold the anchovies! ALL

Cheeseburgers. MICHAEL

With bacon. KATIE

And fries. MATT

Drenched in ranch dressing. JESSIE

Triple chocolate milkshakes. EMILY

Chocolate chip cookies. MATT

With milk. KATIE

Cold milk. MATT

So many things to miss. JESSIE

You could never name them all. EMILY

Never. ALL

(With background music. The tone is sad joy--sad that it's gone, joyful in remembrance. Sometimes they are oblivious of Josh, other times they direct the lines at him. At the director's discretion, cut one or two of the following sections (5 or 10 lines) and let the Actors improvise. Let each actor personalize things they now have that they miss. Let each line begin with, "I miss--". Let none of it interfere with plot, character or tone.)

MICHAEL

I miss cruising, windows down, radio up.

KATIE

I miss lying on my bed in the dark falling asleep to a CD.

MATT

I miss getting shot down by girls.

JESSIE

I miss when a guy gets that look in his eye! And you know he's gonna ask you out!

EMILY

And then he says, Can I borrow your math book?

(These lines begin to overlap.)

MICHAEL

I miss when she answers before you even finish asking--

KATIE

I'd love to!

MATT

I miss when you go in for the kiss and then it happens and it's much, much better than you dreamed it would be.

JESSIE

I miss bowling.

EMILY

I miss seeing Jody when she has that look on her face that she's got another stupid joke to tell me.

MICHAEL

I miss mom's rock-hard brownies.

KATIE

I miss my dog when I come home from school.

MATT

I miss how my dog jumps all over me and barks for a treat.

JESSIE

I miss caffeine.

EMILY

I miss when you take a new pair of jeans in the dressing room and put them on and they fit perfect.

MICHAEL

I miss cheese puffs.

KATIE

I miss soda fizz tickling my nose.

MATT

I miss loving someone.

(Emily gets everyone's attention. They listen.)

JESSIE

I miss fixing my hair in the morning.

EMILY

I miss going to the mailbox and getting a letter that I didn't expect.

MICHAEL

A hand written letter.

(Katie moves DC. The others follow one by one on their lines. This is addressed to the audience.)

KATIE

I miss jumping into a cool pool on a hot day.

MATT

I miss sneezing.

JESSIE

I miss sleeping.

EMILY

I miss good times in Louisiana.

MICHAEL

I miss rollerblading.

KATIE

I miss when you start the school year and you open a book for the first time and the spine cracks.

MATT

I miss going into the cafeteria and deciding who I want to sit with.

JESSIE

I miss laughing so hard I start to cry.

EMILY

I miss waterskiing in Georgia.

MICHAEL

I miss being home alone with a microwave bag of popcorn and the remote in my hand channel surfing.

KATIE

I miss giving my dog a bath and she shakes and gives me a shower.

MATT

I miss mom's cooking.

JESSIE

I miss mom's cooking wafting through the house and trying to guess what it is.

EMILY

I miss picking a college.

MICHAEL

I miss talking with friends on the phone after midnight.

KATIE

I miss going in a grocery store and being able to buy anything I want.

MATT

I miss hanging out.

JESSIE

I miss the end of a race when I'm out of breath and I feel so good about myself.

EMILY

I miss screaming at the football games.

MICHAEL

I miss the end of the day school bell, the feeling in the air when you can go home.

(Katie crosses to a new position to look at Josh. The others follow on their lines.)

KATIE

I miss my bed.

MATT

I miss singing in the shower.

JESSIE

I miss getting into a fight with my brother and acting like nothing happened five minutes later.

EMILY

I miss making mom laugh so hard she can't hardly breathe.

MICHAEL

I miss watching the sky go from light to dark.

KATIE

And dark to light.

MATT

I miss, even at my age, not being able to sleep on Christmas Eve.

JESSIE

I miss learning new songs on the piano.

EMILY (TO DECEASED)

I miss singing to the radio in front of the mirror.

MICHAEL (JOINING IN)

And pretending I'm in concert.

KATIE AND ALL

SRO!

MATT (DECEASED, XC, LINES OVERLAP)

I miss Sunday brunch.

JESSIE

I miss Krispy Kreme donuts.

EMILY

I miss opening a door on a winter's day and feeling the cool rush of cold air on my face.

MICHAEL

I miss hitting on girls.

KATIE

I miss jumping on the trampoline with six people at a time.

MATT

I miss swimming in the fountain at midnight.

JESSIE

I miss people watching.

EMILY

I miss the look in my brother's eye just before he pulls his newest wrestling move on me.

(Music fades out. Josh interrupts.)

JOSH

I never thought I was taking away all that! Never!

MICHAEL

Never? What do you know about never? I'll never do all I wanted to do.

ALL

Never.

KATIE

I'll never achieve my dreams.

ALL

Never.

MATT

I'll never see all I wanted to see.

ALL

Never.

JESSIE

I'll never know all I wanted to know.

ALL

Never.

EMILY

Not ever.

(At the director's discretion, cut one or two of the following sections (5 or 10 lines) and let the actors improvise. Let the actors personalize those things they never had. Let each line begin with, "I'll never--". Let none of it interfere with plot, character, or tone.)

KATIE

I'll never be an aunt.

(Music continues. Characters listen respectfully to each other.)

MICHAEL

I'll never know what it is to live on my own and be independent.

MATT

I'll never have the chance to be a better person.

JESSIE

I'll never go to college and have a double major.

EMILY

I'll never find the right person to spend my life with.

MICHAEL

And make a marriage work.

(Josh, on the outside, moves in, hoping for an invitation. They ignore him.)

JOSH

I miss--

(They drown him out.)

KATIE

And give love.

MATT

And get love.

JESSIE

I'll never meet a beautiful, intelligent, caring
fraternity boy who will look at me and see
perfection.

EMILY

I'll never be married in a white dress and have a
huge wedding.

MICHAEL

I'll never make new friends.

KATIE

I'll never be a psychologist.

MATT

I'll never play catch with my son.

JESSIE

I'll never have long talks at a candle lit table in
the corner of a little restaurant.

EMILY

I'll never be nineteen the way I always dreamed
about.

MICHAEL

I'll never know what it is to come home from work
and open the door and all my kids run to me and pull
me down on the floor and smother me with hugs and
kisses.

KATIE

I'll never find out if the psychic was right--will
I get what I want or sell used cars?

MATT

I'll never know what it is to own my own car.

(Moving DC, to the audience. One by one the rest join
him.)

JESSIE

I'll never have my beautiful frat boy hold my hand
in the delivery room of the maternity ward telling
me to push, push, push while I tell him to shut up.

EMILY

I'll never own a red convertible.

MICHAEL

I'll never fly a plane.

KATIE

Or sail a boat.

MATT

Or see the Dead Sea.

JESSIE

I'll never have three children who look just like my
frat boy so that when I kiss them I'm kissing him.

EMILY

I'll never see my limits.

MICHAEL

Or really know myself.

KATIE

I'll never learn all mom's recipes.

MATT

I'll never have a chance to make dad proud of me.

JESSIE

I'll never cry at my children's graduation.

EMILY

I'll never see Paris.

(Turning to Josh. One by one, each turn on their own
lines.)

MICHAEL

Or Tokyo.

KATIE

Or learn to fly fish.

MATT

Or get washboard abs.

JESSIE

I'll never have an epitaph that reads "Beloved
mother, grandmother, and wife. Died at 17."

JOSH

What do you want from me? I can't bring you back to life! If I could, I would! Don't you see that? It's over! It's over!

MICHAEL

Over for us, Josh.

KATIE

But it's just beginning for you.

MATT

For the rest of your life.

JESSIE

You'll have us in your head until you're dead.

EMILY

And you'll see us over--

MICHAEL

And over--

KATIE

And over--

MATT

Again and--

JESSIE

Again--

EMILY

As you saw us yesterday in the school cafeteria.

CHORUS

DEAD!

(Katie drops dead)

DEAD!

(Michael drops)

DEAD!

(Jessie drops)

DEAD!

(Matt drops)

DEAD!

(Emily throws her arms around Josh, drops. Josh touches her blood and cries out. One light on Josh.)

JOSH

I didn't know it would be forever. I thought it was "bang bang you're dead" again. I thought I could just hit the reset button and start over. Why can't I have another chance? When I killed you I killed all my possibilities, too.

(more)

JOSH (cont'd)

I'll never have anything to look forward to. Never.

(One by one the deceased rise dream-like and
begin to exit slowly turning out their lights.)

Is this the rest of my life?

(Josh goes to his knees, devastated)

Oh God.

(Emily turns out her light on Josh. Darkness.)

END

Bang-Bang, You're Dead / the box...

Design by Mark Huisenga, Thurston High School Tech Director

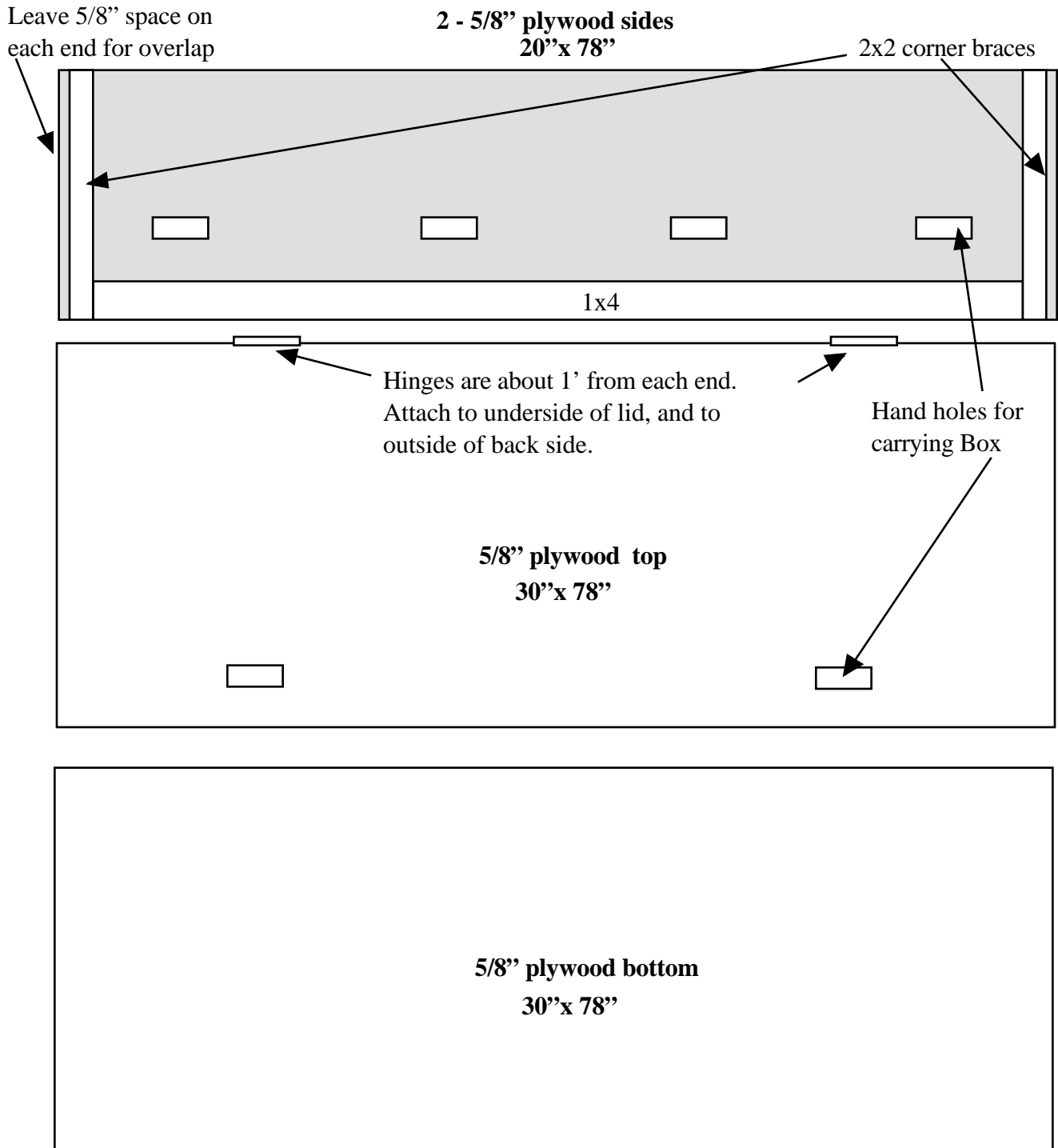

2 - 5/8" plywood ends
20" x 30"

Leave 1 1/2" space for
2x2 corner braces.

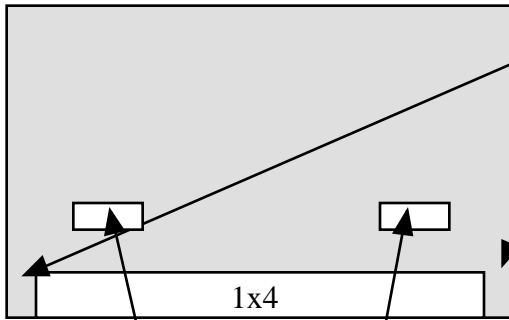

Hand holes for carrying Box

When installing the
bottom, remember
to screw into the
1x4 and 2x2 brace
instead of the edge
of the plywood.

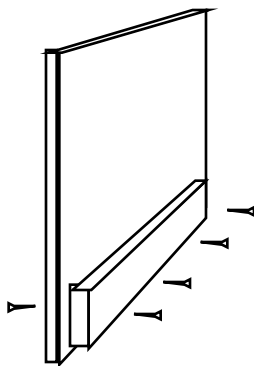
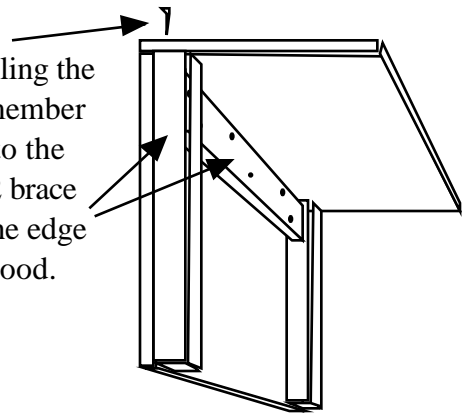

Attach a 1x4 to the bottom
of each side, so that when
you attach the bottom to the
sides, there is solid wood to
screw into, instead of just
the plywood. Screw in
from inside and outside,
and make sure the screws
don't go all the way
through!

Install 1x4 blocks
to strengthen the
hinges.

Brackets hold rope to
stop lid from opening
all the way to protect the
hinges.

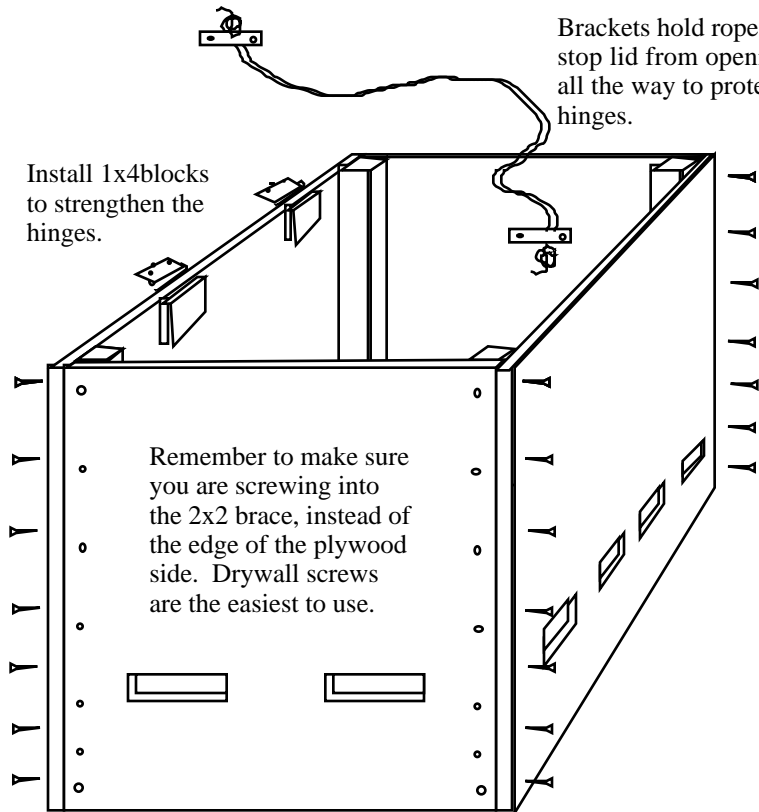

Remember to make sure
you are screwing into
the 2x2 brace, instead of
the edge of the plywood
side. Drywall screws
are the easiest to use.

Pad the inside with 4-6" of foam rubber on bottom, and 3" on sides.